

# ACROKOOOL

# ANTI-MICROBIAL HYDRATION STATION

**Chilled Or Unchilled**

Acrokool's anti-microbial hydration station offers a hygienic solution to keep staff and patients hydrated safely. Our use of special grade stainless steel means it is easy to maintain and to clean. We have designed the dispensing area specifically to fit one plastic cup size to eliminate personal bottles touching the spout. The water dispenser is approved by the UCLH anti-infection unit.



Environmentally  
Friendly



Antimicrobial  
Copper Piping



Durable materials,  
tamper proof



Designed & Manufactured in the UK



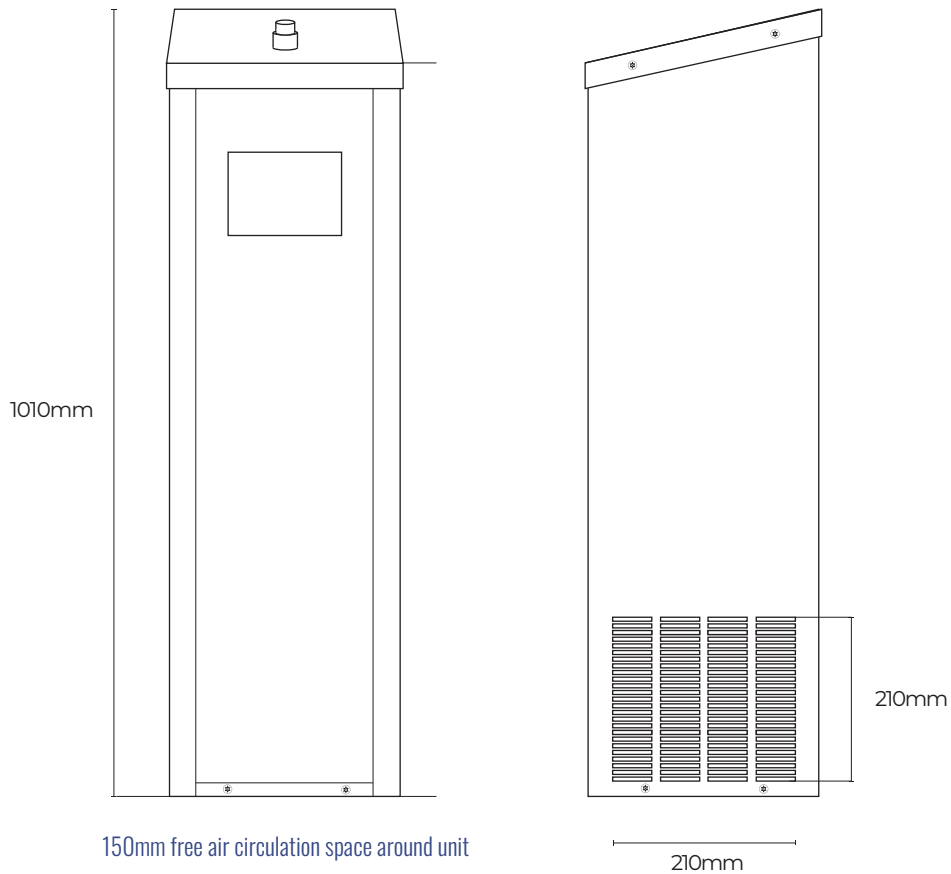
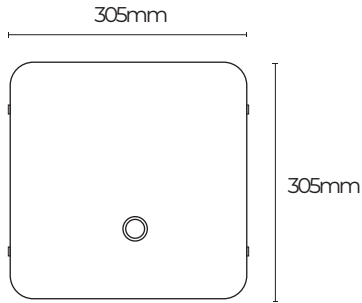

Operation	Manual Or Sensor Button
Choice Of Internal Filtration	8" Carbon Block 10 Micron
H x D x W (mm)	1010 x 305 x 305 (mm)
Cabinet	Black Plastisol Coated Galvanised Steel / Brushed Stainless Steel
Wall Mounted Security Brackets	Long 750mm / Short 421mm
Waste Option(s)	1 1/4" P' Trap
Weight (kg)	35 (kg)
Chilled Water Production	Up to 50 Litres per hour
Unchilled Water Production	Up to 50 Litres per hour
Cooling System (Chilled)	Direct Chill Coil On Coil
Rated Input	180 Watts
Water Temperature	8 - 10 C
Water Options	Cold
Dispensing Height	950mm
Electrical	230v / 50Hz   13Amp Plug
Water Inlet	1/4" Bulkhead



**Designed & Manufactured in the UK**

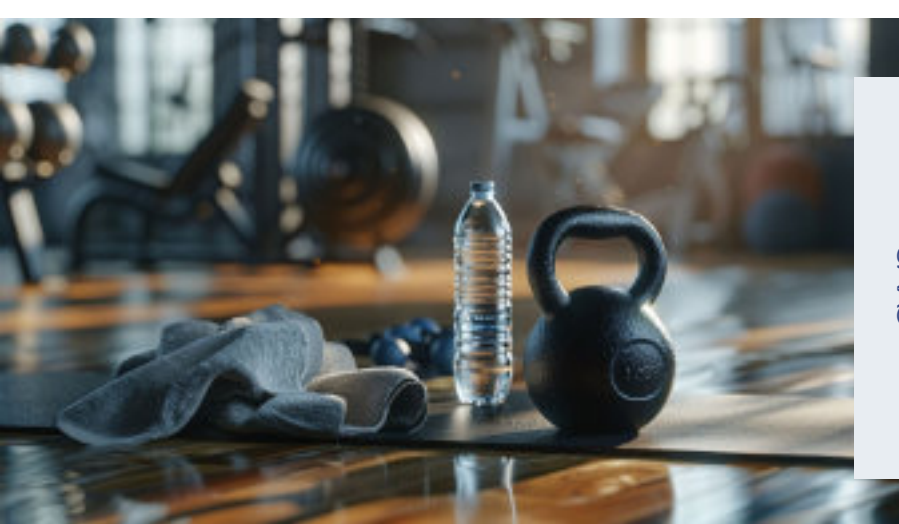

GYMS



Chills only the water you use.



Anti-microbial chill pipes for clean drinking water.



Easily maintained



Easy to install.



HOSPITALS



12 months parts warranty

**Useful Feature:**

**Slanted top to stop users placing cups down avoids spillages.**



OFFICES



Brushed Stainless Steel





# ACROKOOOL

[bottlefilling.co.uk](http://bottlefilling.co.uk) | 01799 513631 | [hello@bottlefilling.co.uk](mailto:hello@bottlefilling.co.uk)  
Acrokool Ltd, Chroma House, Shire Hill, Saffron Walden, CB11 3AQ